

Fabrication

#5 Routing

This brief gives advice for:

- **Equipment**
- **Procedures**
- **Trouble Shooting**
- **Equipment Suppliers**
- **Additional Technical Information and Assistance**

Equipment

Manual Feed Routers

Many commercially available types of routers are acceptable. These include hand held routers, table routers, pin routers and fixed position routers. The router should have a minimum of one horsepower and a no load speed of 20,000 RPM.

CNC (Computer Numerical Controlled) Routers

Computerized Numerical Control (CNC) machines are available from several manufacturers for high volume production. Today there are many companies manufacturing CNC routers servicing industries that fabricate wood, metal and plastic products. As a result, a variety of machine designs are available to fit the job demand.

Light duty routers made for engraving or routing thin (.118") single sheet, are commonly fitted with one to three horsepower spindle motors. Medium duty routers as seen in the sign industry use four to seven horsepower motors. Large volume and multiple head routers have motors ranging from seven to twenty horsepower.

There are three basic machine designs:

Gantry type machines have an overhead beam that supports one or more routing heads or motorized spindles on a column. The column can be programmed to travel along the gantry beam both horizontally and vertically. The beam itself rides on two vertical supports that travel along parallel tracks set on both sides of a stationary worktable. This facilitates a third axis of movement.

Stationary bridge machines are similar to gantry type machines except that the bridge is stationary. The third axis of movement is facilitated by a worktable that can move in a horizontal plane perpendicular to the stationary bridge.

Machining centers originate in the tool industry. They offer higher precision and are commonly used for the production of small component parts. These machines typically have smaller worktables than the stationary bridge or gantry machines and carry a higher price, corresponding to their accuracy and versatility.

All of these CNC machine types are available for purchase with hardware and software to facilitate machining on 2 ½, 3, 4 and 5 axis. There are machines suitable for any requirement from fabrication of small prototypes to large part production runs. CNC machines can handle repetitive production cycles, using one or two tables. They are also available with multiple routing heads or spindles, so several parts can be produced at the same time. Options such as turret heads and tool changing spindles to facilitate tool changes without stopping the machine are available. CNC machines can be set up for semi-automatic or fully automatic operations that incorporate material pallet changers and automated loading and unloading equipment.

If business demands justify a step up in production, CNC routing is one of the best ways to increase productivity, as well as assure reproducible results and quality.

Router Bits

Router bits may be made of high-speed steel (HSS), carbide-tipped, solid carbide or diamond-tipped. They can be one piece, multiple part, bearing guided, straight cutting, forming or specialty bits.

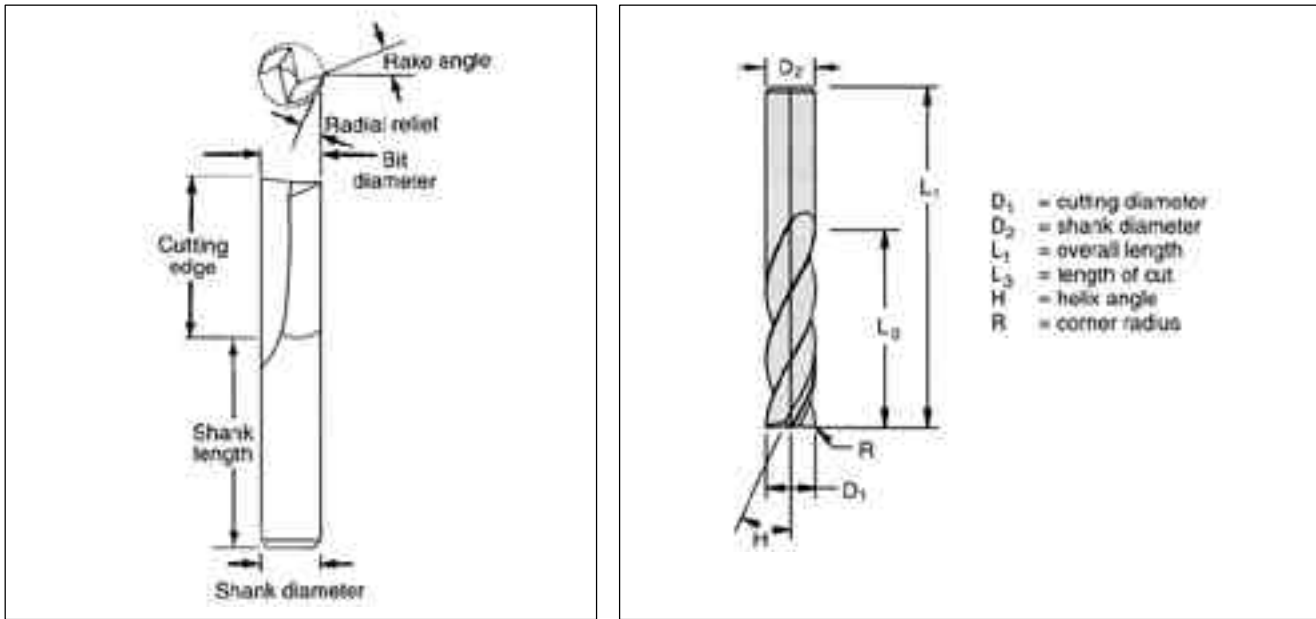

Router bits for machining acrylic may consist of one to three flutes. Single and double fluted bits are commonly used. When using HSS or brazed carbide bits, the length of the cutting edge should not exceed three times the diameter of the tool or a ratio of 3 to 1. With the proper use of solid carbide bit technology, this ratio can be increased to 4.5 to 1. Bit shank diameter should always be equal to or larger than the cutting tool diameter. The length of the shank should be long enough so that the entire cutting edge is usable. Bits should be mounted in a clean collet chuck and set to allow maximum tool bit support and flute clearance to facilitate chip ejection.

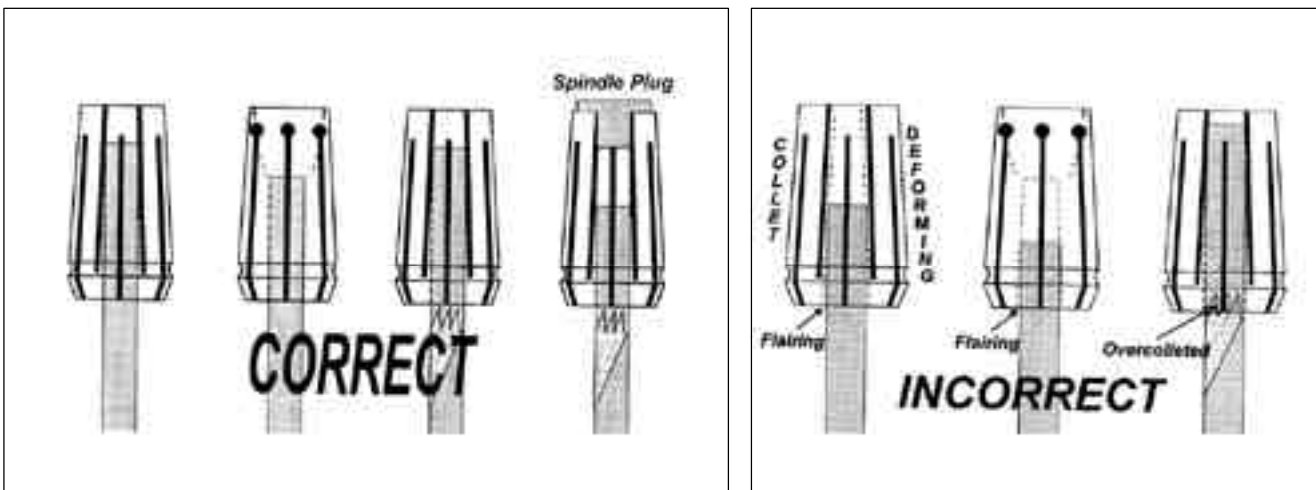

For hand held routing, two-flute straight bits are usually recommended.

For table routers, pin routers and fixed position routers, single-flute or two-flute bits can be used. Single flute straight bits will give good results when contour routing. Single or double flute up-spiral bits will produce better results when cutting grooves or channels since the up-spiral configuration will assist in removing chips. Both "O" flute and "V" flute geometries work well.

When processing acrylic using a CNC router, solid carbide, up-spiral "O" flute router bits will produce the best results. They are available with one, two or three flutes. Common bit sizes are 1/8" to 1/2" diameter. These bits are less susceptible to friction and heat build up because the O-flute design allows chips to curl naturally as they are formed and facilitates better evacuation of the chips from the cutting area. In less demanding applications, standard twist bits (V-flute geometry) can also be used with success.

In general, up-spiral bits are recommended because they pull chips up and out of the way, reducing frictional heat build-up. However, when material hold down is an issue, straight flute or down-spiral geometries may be beneficial. Increasing the number of flutes on the bit will usually result in a better quality finish on the edges of the routed surface. However, tooling cost also increases with the number of flutes on the bit. Therefore, it is best to start with a one or two flute bit and only step up to a higher number of flutes if necessary.

Tools with a single flat-faced cutter are commonly employed for engraving applications. These include profile cutters, parallel cutters and braille cutters. Rigidity is important so solid carbide tools should be used. When engraving letter widths greater than 0.060", other router bit types may be necessary to provide the desired finish on the inside of the letter. These include V-grooving, veining, up-spiral ball nose and double-edge bottom surfacing bits.

Tool Maintenance

The cutters should be kept sharp. Chipping or overheating will occur with a dull cutter. Both will impart stress into the sheet.

Procedures

Be sure to follow the manufacturers' safety recommendations for equipment and materials used with ACRYLITE® FF acrylic sheet.

Safety

When using routing equipment always wear protective face shields or safety goggles. Hearing protection is recommended for extended periods of routing. If a vacuum system is not used, a respirator or dust mask will offer protection from dust particles.

Hand Routing

Prototype and replacement parts can be produced using a hand router. The router is guided around a precut template pattern that is fastened to the acrylic sheet. The template is typically held to the sheet using vacuum or two-sided adhesive tape. Clamps may also be used to

hold the template to the material and moved when necessary. Templates can be made from plywood, fiberboard or rigid plastic. A hand-held router can be piloted around the pattern in several ways. Offsets can be calculated making allowances for the router sub-base, template guide, or a piloted bearing follower bit.

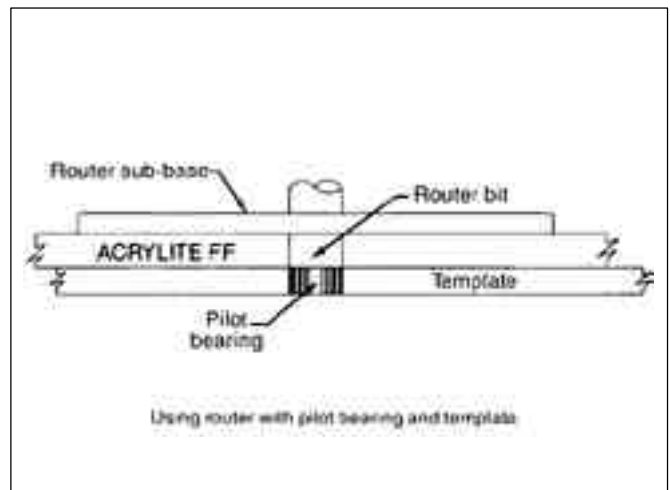
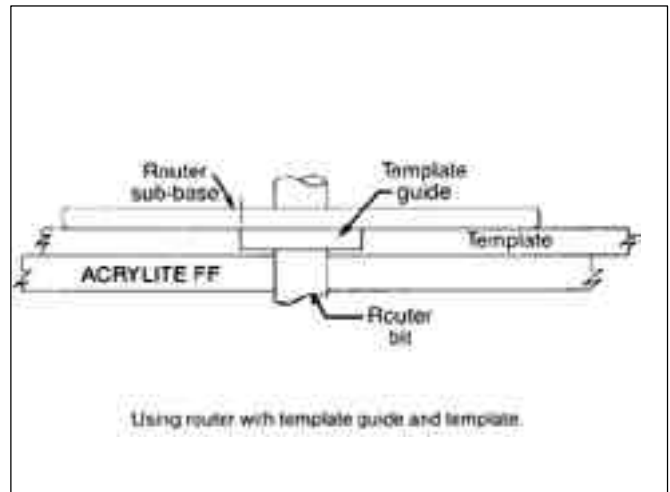
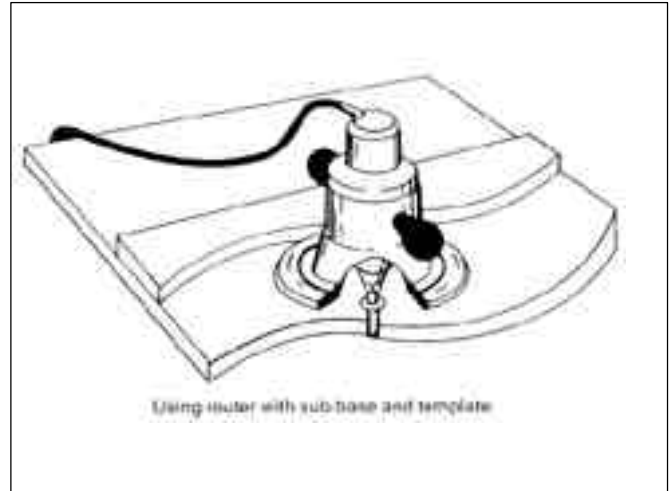

Circle Routing

Circles of varying diameter can be fabricated with a cutting fixture consisting of a fixed position router and a sliding adjustable rotary table. The adjustable table is mounted on a sliding shaft and column. This can be adjusted for variable center distances. The sheet is held on the rotating table with vacuum. Once set up, the sheet is moved into the cutter and rotated 360° to machine the circle. This method allows for easy machining and size adjustment. It can also be adapted to machine other shapes by following a pattern. Circles can also be cut using a hand router and precut circle templates.

Pin Routing / Overhead Routers

Pin routing machines are very versatile. Pin routers utilize a horizontal column to support a pneumatically activated guide pin. This pin is set directly over a spindle which holds the router bit below the worktable. Both the pin and router bit are fed to a preset stop and are activated by a foot pedal. Plunge routing can be accomplished using this feature. The template has the material to be machined fastened below it. An operator feeds the template along the table to the pin and then guides the top edge of the template along the pin. As the template is rotated 360° around the pin, the rotating router bit cuts the material fastened below the template. The material is commonly fastened to the template using double-stick tape or vacuum. Overhead routers work in the same manner with the router and pin locations inverted.

Contour Routing

Pin routing machines may also be used for multiple part, stepped or contoured part manufacture. To accomplish this a contour jig must be employed. The desired pattern is cut on the base of the contour jig to match a depth stop preset below the worktable. Several pieces of material are secured to each other to form a stepped template. The cutting tool is then guided by a series of step pin stops set below the worktable. These pins control the cutting depth of the router bit. The process does not cut all the way through the sheet. The material is only separated following the final cut. This multi-cut process enables the cutting of contoured patterns.

Engraving

Machining ACRYLITE FF sheet using engraving bits requires the correct spindle speed (RPM), feed rate (IPM) and depth of cut. The ability to remove chips and keep the sheet cool while cutting is a key consideration when engraving. Speeds should be set at 9,000 to

10,000 RPM and feed rates at 55 to 65 IPM. In general, chip loads (IPT) of 0.003" to 0.006"/tooth should be used for engraving applications (refer to the Operation Terminology and Formulas section for more details). Machines will vary in performance so this information should only be used as a starting reference.

Computerized Numerical Control (CNC) Routing – Machine Characteristics and Fixturing

In order to optimize machining on a CNC router, there are several key points to consider. The first is the machine type and condition. This includes the integrity of the spindle, the selection and condition of the collets, the machine table and the fixturing. The quality of the equipment and fixtures being used will have a significant impact on the rate at which parts can be processed and the quality of the finished parts.

Fixturing or part hold down will change with the part design and size. The most common way of holding material on a CNC routing table is by using vacuum to hold parts onto a spoilboard base. Spoilboard is a medium density fiberboard (MDF) that can be machined or milled to facilitate part hold down. The two types commonly used are: Conventional Vacuum Spoilboard and Universal Vacuum Spoilboard.

Conventional Vacuum Spoilboard is used in conjunction with a high vacuum, low volume pump. Generally fixtures are specially designed for the parts being processed and therefore different fixtures are required for each part design. Fixtures are made by machining grooves into the spoilboard to supply vacuum to the part. A gasket is usually attached to the spoilboard just inside the outer contour of the part to help maintain a good vacuum seal between the part and the spoilboard. This type of fixture provides the greatest holding force for the part.

Universal Vacuum Spoilboard is used in conjunction with a low vacuum, high volume pump to provide vacuum through the pour structure of the entire spoilboard. Material laid on the spoilboard will be held in place once the vacuum is turned on. The advantage of this board is that it does not require grooves to direct the vacuum or gasket to ensure a good seal. As a result, a single spoilboard base can be used for many different part designs. Universal vacuum spoilboards are not recommended for working with small parts or parts with rough surfaces.

Other methods of part hold down include: bolting down the material, using cam lock clamps, and holding the work in a vice that is bolted to the router table.

Processing Parameters

The part requirements and how they impact processing must be considered. Knowing the depth of cuts to be made, the minimum inside radius required on the finished part and the edge finish quality requirements will guide the selection of tooling and processing parameters. Typical processing parameters will include the number of tool bit passes chosen to complete the part and whether or not the part needs to be roughed to shape before finishing passes are made to achieve the desired finish.

Machine horsepower and work hold-down (or fixturing) are the two factors affecting the amount of material that can be removed during each cutter pass. When multiple passes are required, start with a large diameter roughing cutter to remove the bulk of the material. Keep the part minimum inside radius in consideration for secondary and/or finishing passes. In most cases, two cutters are used to machine parts to shape, one for roughing and one for finishing. In some cases, three cutters may be required to complete the part and achieve the desired edge finish and inside radius.

For determining the depth of cut (DOC) to make on each pass, the following guidelines can be used:

Face Milling

Use a material removal ratio of 3:2. For example if the cutter diameter is 3", then a 2" cut is the maximum depth of material that can be removed per pass.

Routing/Periphery Milling

Start with a 0.100" depth of cut per pass and increase the DOC to 1/2 - 2/3 the cutter diameter. Note: The cutter edge length (CEL) listed by the cutter manufacturer may be fully engaged as required. Many single flute up-spiral and center cutting bits can be plunged or programmed to ramp in and take the full cutter diameter for slotting and part cut out. The DOC for a finishing pass should be no less than .010" and provide a chip load of at least 0.004"/tooth (refer to the section Operation Terminology and Formulas for more details).

Operating Conditions

Once the optimum processing parameters have been determined, consideration must be given to the operating conditions for the CNC router. This includes settings for the spindle speed and cutter feed rate through the material. Rotational speeds of 16,000 to 18,000 revolutions per minute (RPM) and feed rates of 100 to 300 per minute (IPM), normally produce the best results with 1/4", 3/8" and 1/2" diameter bits.

For smaller bits (1/8" and 3/16") rotational speeds of 18,000 to 20,000 RPM, with feed rates of 100 to 200 IPM range will produce the best edge and tool life.

It is important to note that dust/chip collection systems as well as coolants such as compressed air, mist coolants and cold air/vortex tube technology, will greatly reduce the heat build up and improve the quality of the edge as well as extend the life of the tool.

Direction of Travel

Proper feed direction is essential for a smooth cut. Routers rotate clockwise when viewed from the spindle or colleted side of the router. This is also referred to as Right Hand Cutting. If a hand held router is fed into the sheet in a clockwise direction, the cutting edges of the bit will pull the bit into the work rendering control nearly impossible. This routing method is referred to as Climb Cutting. Climb Cutting should only be used on machinery that has rigid spindles and worktables that are free of leadscrew backlash. Climb Cutting will improve product surface finish and increase tool life.

Note: This type of machining can only be done on CNC machinery. Climb Cutting is not recommended for most routing applications.

The feed direction for external cuts should be counter-clockwise. When routing inside edges, the router should be fed clockwise. This practice will allow an operator to maintain proper control of the router and attain a smooth edge. This method is referred to as Conventional Cutting.

Note: Conventional Cutting is the recommended method for most routing operations. Refer to the routing direction diagram on page 6.

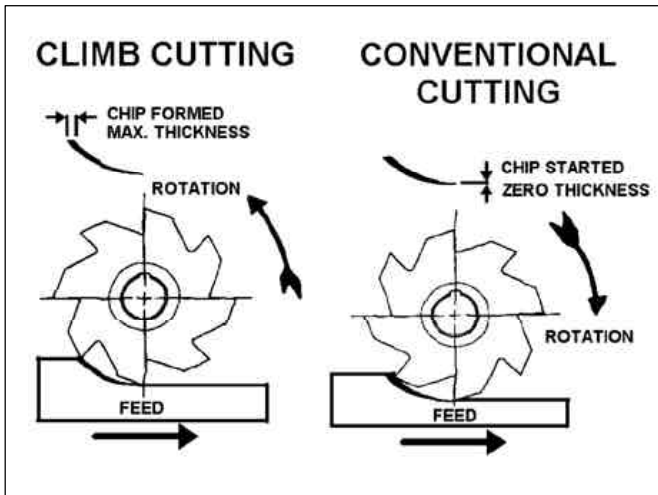

Slotting, routing shapes out of a sheet, periphery routing, and cutting a part by machining around the outside edge of the part, employ both conventional and climb routing. Care should be taken in the machining techniques and programs to allow for the desired finish.

Vibration

It is of the utmost importance that balance of the tool, collet and spindle is maintained so that vibration is kept to a minimum. Even small vibrations can introduce stress that will eventually result in crazing and fractures in acrylic sheet during fabrication or use. The maintenance of spindles and collets is a key factor in controlling vibration. The spindle and collet must be thoroughly cleaned every time there is a bit change.

Operation Terminology and Formulas

Cutting Edge - The leading edge of the cutter tooth.

Flute - The space between the back of one tooth and the face of the following tooth.

Axis - The imaginary straight line that forms the longitudinal center line of the cutter.

Helix Angle - The angle that is formed as the cutting edge spirals around the outside of the tool. It is measured relative to the axis of the tool.

Shank - The portion of the cutter that is held in the spindle in order to drive the tool.

Diameter - Equals the largest outside cylindrical dimension of the cutting tool, measured at the cutting

edge. Cutter diameter is normally dictated by the design of the part. The key consideration is material removal. Initial machining steps should employ the largest cutter diameter to rough out the part. Secondary cutting operations should utilize bits that match the proper radius or leave the required edge and surface finish on the sheet.

Speed – Surface Feet Per Minute (SFM) is the actual speed at which the cutting edge of the tool is striking the material. It is used to determine spindle revolutions per minute (RPM). There are two formulas that relate these two values and take into consideration the tool bit diameter.

$$\text{SFM} = .262 \times \text{Diameter (inches)} \times \text{RPM}$$

$$\text{RPM} = 3.82 \times \text{SFM} / \text{Diameter (inches)}$$

For most operations the RPM commonly runs between 10,000 to 20,000. Depending on bit diameter, the speed can be as low as 300 SFM and may run as high as 2400 SFM although it more commonly runs from 500 to 1500 SFM. This will change based on the demand for material removal and edge finish requirement. This is the first of three factors that will affect material finish.

Chip load - Inches Per Tooth (IPT) corresponds to the amount of material removed by each tooth of the cutter every time it contacts and passes the material. Sufficient chip load will create stability between the cutter and the work piece. The optimum chip load for acrylic sheet is .004" to .015"/tooth.

Feed Rate – Inches per Minute (IPM) is the distance that the cutting tool travels along the edge or surface of the material being processed in one minute. The proper range for feed rate can be determined by considering the chip load. Operating in the lower part of the recommended range for chip load will tend to provide a better finish but at the expense of throughput. Operating at the high end of the recommended range for chip load will result in a rough finish on the part but higher part throughputs. Typical feed rate parameters for ACRYLITE FF sheet range from 100 to 300 IPM. To establish the feed rate knowing the desired chip load, the number of cutting edges on the bit and the RPM use the following formula:

$$\text{IPM} = \text{IPT} \times \text{No. Teeth} \times \text{RPM}$$

Trouble Shooting

Problem	Cause	Solution
Chipped Edges	Dull tool	Replace or sharpen tool
	Spindle speed too slow	Increase speed (RPM)
	Feed rate too fast	Reduce feed rate (IPM)
	Vibration	Clamp securely
	Rigidity	Check fixture clamping Improper mounting
	Cutter Damage	Improve storage and handling. Cutters should not be thrown unprotected in drawers.
	Total Indicator Run-Out (TIR)	Check tool and tool holder for run-out
	Defective or worn collets	Replace
	Bearing wear	Replace when tool run out exceeds .001-.002 inches
Chatter	Rigidity	Check holder Check machine for wear Use shortest possible cutting tool
	Spindle speed too high	Decrease spindle speed (RPM)
	Chip load too high	Decrease feed (IPT)
	Fixturing	Check for part movement
Melted Edges	Dull tool	Replace or sharpen tool
	Feed rate too low	Increase feed rate (IPM)
	Spindle speed too high	Decrease speed (RPM)
	Chip load too low	Increase feed (IPT)
	No cooling	Add air or water mist cooling
Plastic melt or plastic chips sticking to bit	Tool finish	Rough bit finishes allow material to adhere to cutting edge. Use bit with polished flute.
Chip Packing	Too many flutes on bit	Make sure flute space is adequate Use only one or two flutes for roughing
	Plunge cutting	Use two flute up-spiral bit Incorrect helix angle
	Depth of cut too large	Make multiple passes
Tool Breakage	Exceed tool strength	Reduce feed rate Reduce cutting edge length Increase diameter of cutter Reduce depth of cut
	Rigidity	Check machine and part deflection Ensure tool is fully engaged in chuck Use the largest diameter bit Use shorter bits
	Cutter misaligned in collet	Correct cutter alignment
	Defective or worn collets	Replace
	Bearing wear	Replace when tool run out exceeds .001-.002 inches
Tool Burning	Dull tool	Sharpen or replace tool
Carbide Chipping	Loose collet	Tighten shank in collet
	Deflection	Ensure shank is fully engaged in chuck Use shorter cutting edge Use larger diameter tool
	Incorrect chip load	Increase number of flutes Reduce feed rate
Causes of Premature Wear	Excess heat	Increase chip load (reduce spindle speed or increase feed rate)
	Tool alloy	Use more wear resistant alloy (carbide)
	Coolant	If coolant is used, it should be clean and high quality. Use cold air gun or compressed air.

Equipment and Materials Suppliers

The suppliers listed below offer materials and equipment tested and approved by CYRO Industries. Authorized ACRYLITE Sheet Distributors may also offer materials and equipment. Visit www.cyro.com for a list of authorized CYRO sheet distributors.

Router Bits

Ekstrom, Carlson & Co.

5196 27th Avenue
P.O. Box 1611
Rockford, IL 61109
815-394-1744
Fax: 815-398-9439
www.ekstromcarlson.com

Great Lakes Carbide Tool Mfg., Inc.

101 N. Old Peshtigo Road
Peshtigo, WI 54157
715-582-3884
Fax: 715-582-4373
www.glct.com

Kennametal, Inc.

1600 Technology Way
Latrobe, PA 15650-0231
724-539-5000
800-446-7738
www.kennametal.com

Onsrud Cutter, Inc.

800 Liberty Drive
Liberty, IL 60048
800-234-1560
Fax: 800-557-6720
www.onsrud.com

Paso Robles Carbide, Inc.

731-C Paso Robles Street
Paso Robles, CA 93446
805-238-6144
Fax: 805-238-4263

Toolmasters LLC

1400 Railroad Avenue
PO Box 1611
Rockford, IL 61110
815-968-0961
Fax: 815-968-5559
www.toolmastersllc.com

Trend Lines, Inc.

100 Justin Drive
Chelsea, MA 02150
800-767-9999
Fax: 800-735-3825
www.trend-lines.com

Union Butterfield

P.O. Box 50000
Asheville, North Carolina 28813
800-222-8665
Fax: 800-432-9482
www.unionbutterfield.com

Wisconsin Knife Works

2505 Kennedy Drive
Beloit, WI 53511
800-225-5959
Fax: 800-336-1254
www.wkwinc.com

Woodworkers Supply

125 Jay Lane
Graham, NC 27253
800-645-9292
Fax: 800-853-WOOD
or 336-578-1401
www.woodworker.com

[Continued on next page](#)

Collets and Tool Holders

Centaur Precision Tools Inc.

13098 SW 133 Court
Miami, FL 33186
888-COLLETS
Fax: 305-251-0756
www.centaurtools.com

REGO-FIX Tools

7752 Moller Rd.
Indianapolis, IN 46268
800-734-6349
Fax: 317-870-5955
www.rego-fix.com

Routers

Black & Decker Mfg. Co.

701 E. Joppa Road
Towson, MD 21287
410-716-3900
www.blackanddecker.com

C.R. Onsrud, Inc.

867 S. Main Street
Troutman, NC 28166
704-528-4528
Fax: 704-528-6170
www.cronsrud.com

Delta International

4290 E Raines Road
Memphis, TN 38118
800-223-7278
Fax: 800-535-6488
www.delta-portercable.com

Gerber Scientific Products, Inc.

151 Batson Drive
Manchester, CT 06040
800-222-7446
Fax: 860-645-5645
www.gspinc.com

KOMO Machine, Inc.

11 Industrial Blvd.
Sauk Rapids, MN 56379
800-255-5670
Fax: 320-656-2470
www.komo.com

MultiCam, Inc.

8920 North Royal Lane
Irving, TX 75063
972-929-4070
Fax: 972-929-4071
www.multicam.com

SB Power Tool Corp.

4300 W. Peterson
Chicago, IL 60646
888-394-4646
800-301-TALK
Fax: 800-547-1998

Shoda CNC Routers

www.shodausa.com
www.boschtools.com

SkilTools

877-754-5999
www.skiltools.com

Thermwood Corp.

P.O. Box 436
Dale, IN 47523
800-533-6901
Fax: 812-937-2956
www.thermwood.com

Additional Technical Information and Assistance

We invite you to visit our TechKnowlogy Center on www.cyro.com.

Visitors have immediate access to frequently asked questions, technical concerns, physical properties, processing conditions, fabrication tips, regulatory compliance information, engineering guidelines, tips for troubleshooting, and hundreds of other facts about acrylics from one of North America's leading manufacturers of acrylic-based polymer and sheet products.



Technical Service

For more information or specific questions about your project, contact CYRO's Technical Service Representatives.

CYRO Industries

25 Executive Blvd.
Orange, CT 06477
203-795-6081

CYRO Canada Inc.

6285 Northam Drive
Suite 100
Mississauga,
Ontario L4V 1X5
905-677-1388
800-268-4743

Sales Offices

For the name of your local Authorized Distributor, call 800-631-5384, visit www.cyro.com, or contact the nearest regional sales office:

Eastern Region

100 Enterprise Drive
PO Box 5055
Rockaway, NJ 07866
973-442-6130

CYRO Canada Inc.

6285 Northam Drive
Suite 100
Mississauga,
Ontario L4V 1X5
905-677-1388
800-268-4743

South/Central Region

101 East Park Blvd.
Suite 1039
Plano, TX 75074
972-424-6830

International

100 Enterprise Drive
PO Box 5055
Rockaway, NJ 07866
Fax: 973-442-6083

Western Region

3180 Crow Canyon Place
Suite 240
San Ramon, CA 94583
925-866-9300

Web site: www.cyro.com

Fire Precautions

ACRYLITE FF sheet is a combustible thermoplastic. Precautions should be taken to protect this material from flames and high heat sources. ACRYLITE FF sheet usually burns rapidly to completion if not extinguished. The products of combustion, if sufficient air is present, are carbon dioxide and water. However, in many fires sufficient air will not be available and toxic carbon monoxide will be formed, as it will when other common combustible materials are burned. We urge good judgement in the use of this versatile material and recommend that building codes be followed carefully to assure it is used properly.

Compatibility

Like other plastic materials, ACRYLITE FF sheet is subject to crazing, cracking or discoloration if brought into contact with incompatible materials. These materials may include cleaners, polishes, adhesives, sealants, gasketing or packaging materials, cutting emulsions, etc. See the Tech Briefs in this series for more information, or contact your ACRYLITE Sheet Distributor or the CYRO Technical Center for information on a specific product.

Important Notice

The information and statements herein are believed to be reliable but are not to be construed as a warranty or representation for which we assume legal responsibility. Users should undertake sufficient verification and testing to determine the suitability for their own particular purpose of any information or products referred to herein. NO WARRANTY OF FITNESS FOR PARTICULAR PURPOSE IS MADE. Nothing herein is to be taken as permission, inducement or recommendation to practice any patented invention without a license.

CYRO Industries, Rockaway, New Jersey 07866

